



FD 73 Installation Package

Configurations

2 Panel, 4 Panel, 6 Panel, 8 Panel, and 10 Panel

TABLE OF CONTENTS:

Title Page.....Pg.1

Table of Contents.....Pg.1

Tools Required.....Pg.2

Elevation View Parts List.....Pg.3

Plan View Parts List.....Pg.4

Elevation View Drawing.....Pg. 5

Plan View Drawing.....Pg. 6

Installation Steps.....Pg.7

Step 1: Bottom Track.....Pg.7

Step 2: Jambs.....Pg.7

Step 3: Top Track.....Pg.8

Step 4: Rollers.....Pg.8

Step 5: Leveling Platform.....Pg.9

Step 6: Panel #1.....Pg.9

Step 7: Panel #2.....Pg.9

Step 8: Panel #3.....Pg.10

Step 9: Panel #4.....Pg.10

Step 10: Load and set all rollers.....Pg.10

Step 11: Adjusting the jambs.....Pg.10

Step 12: Bi-fold Handle.....Pg.10

Step 13: Waterproofing.....Pg.11

Operation.....Pg.12-13

TOOLS REQUIRED

- ❖ Laser Level
- ❖ Drill
 - #1, #2, #3 Robertson Bit.
 - #2 Phillips
 - 1/8" Drill Bit
- ❖ Tape Measure
- ❖ Allen Keys
 - 2.5mm, 3mm, 5mm
- ❖ Cedar Shims
- ❖ Hammer
- ❖ Caulking
- ❖ 1x4" or 2x4" Shims

Ex.



- ❖ Richards Bar (recommended)
- ❖ Knife
- ❖ Rod 1/2" (for water proofing)

* If Drilling into Concrete

- ❖ Hammer Drill
 - 5/16" Drill Bit
 - Nylon Plugs (8mm x 40mm) – 5/16" x 1 1/2"

FD 73 SECTION VIEW PART LIST

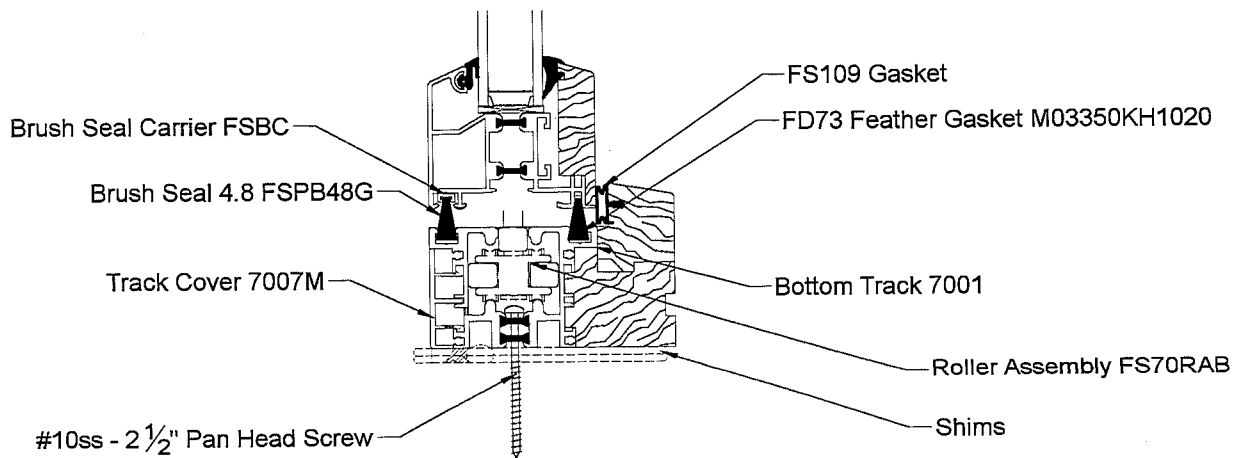
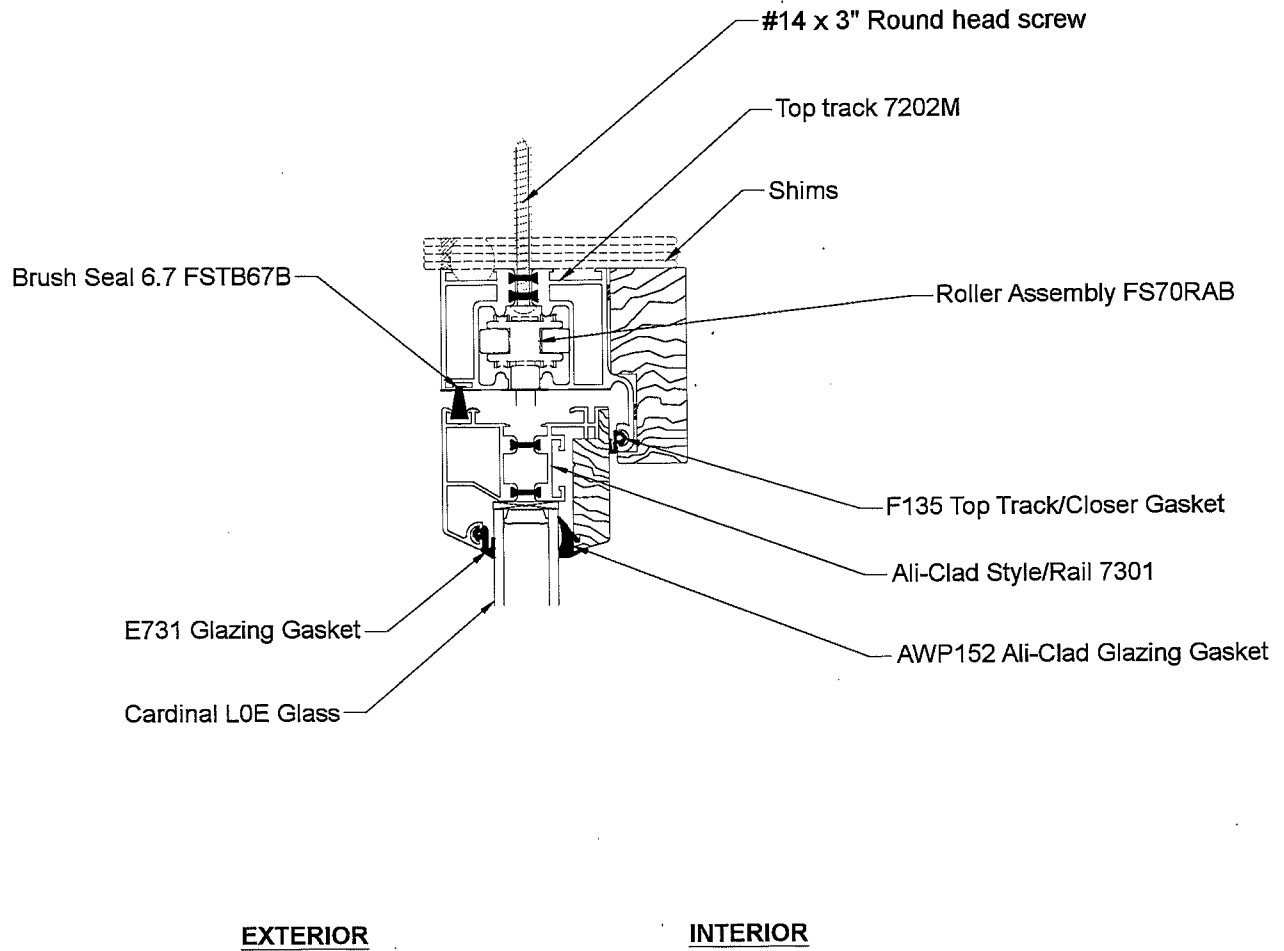

FD 73. PLAN VIEW PART LIST

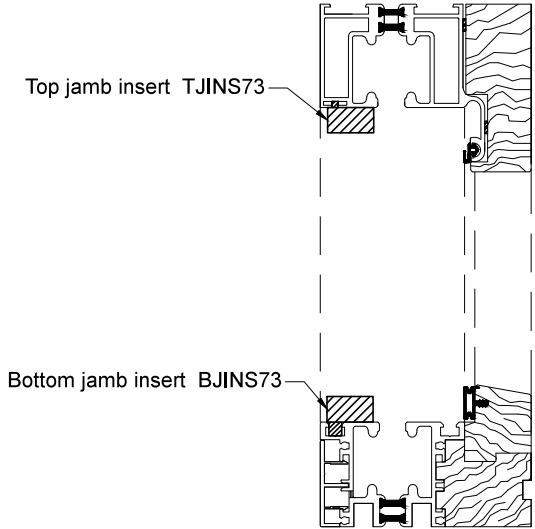
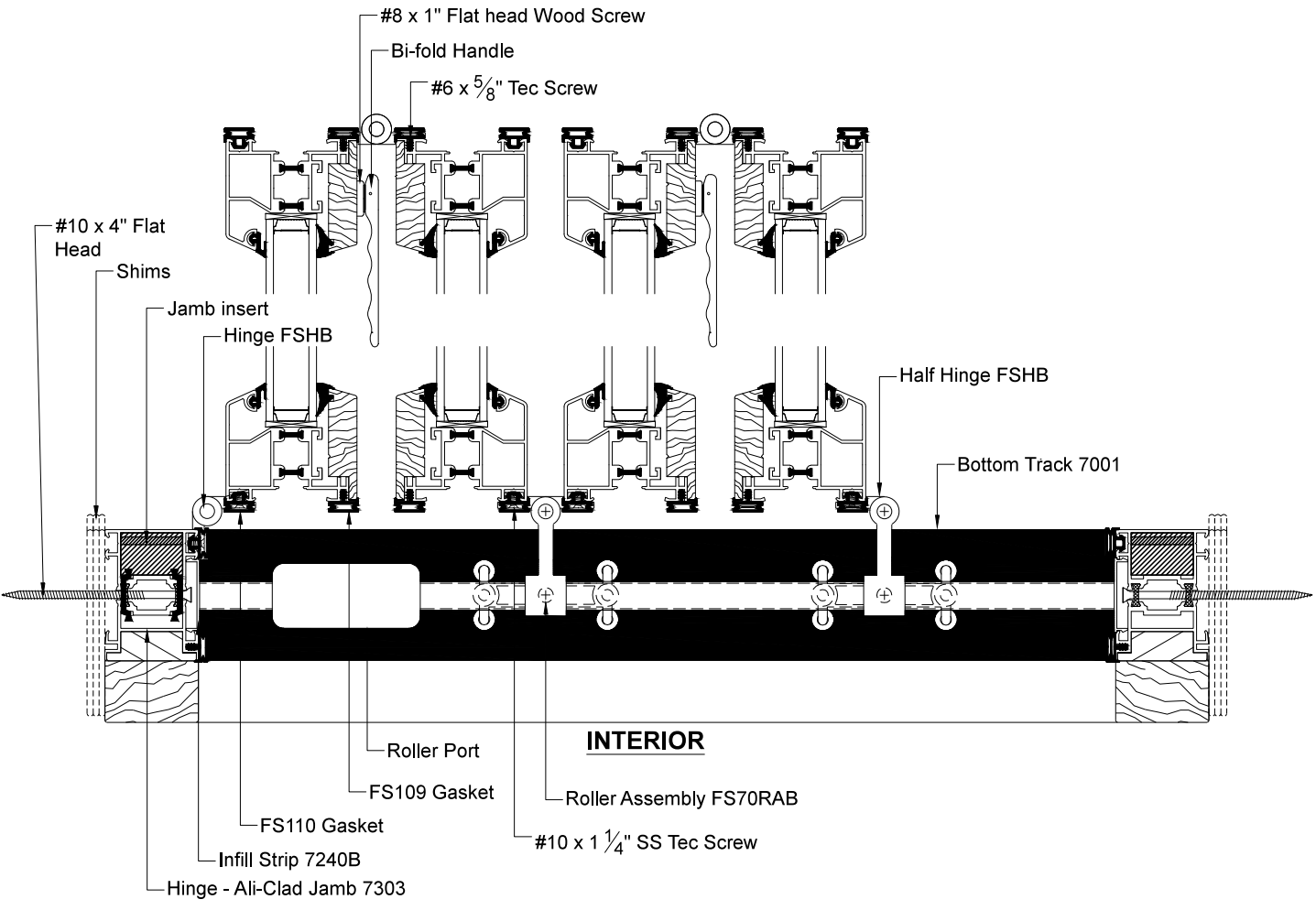

FD 73 ELEVATION VIEW DRAWING

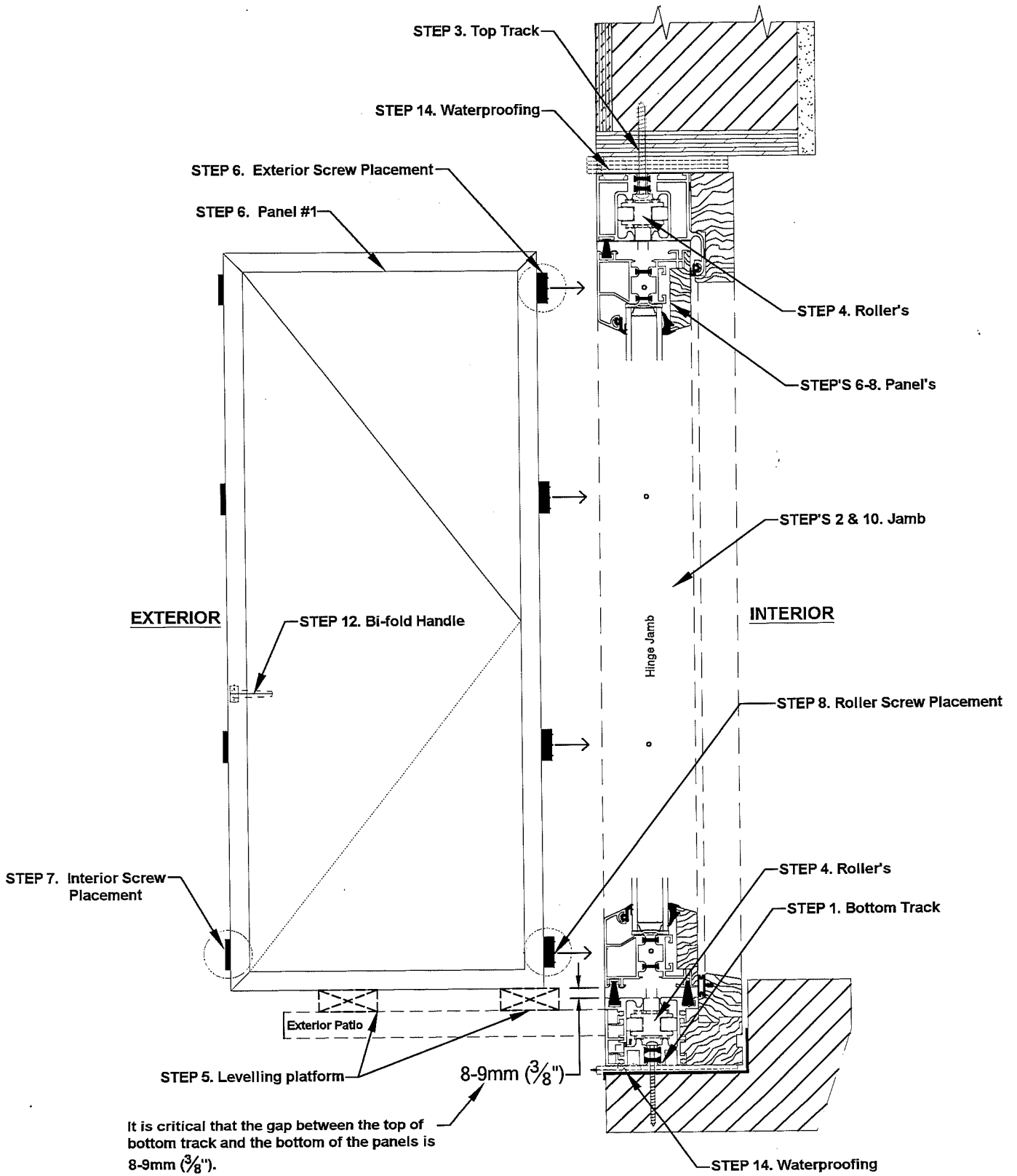

FD 73 PLAN VIEW DRAWING

CONFIGURATIONS: 2 Panel, 4 Panel, 6 Panel, 8 Panel, and 10 Panel

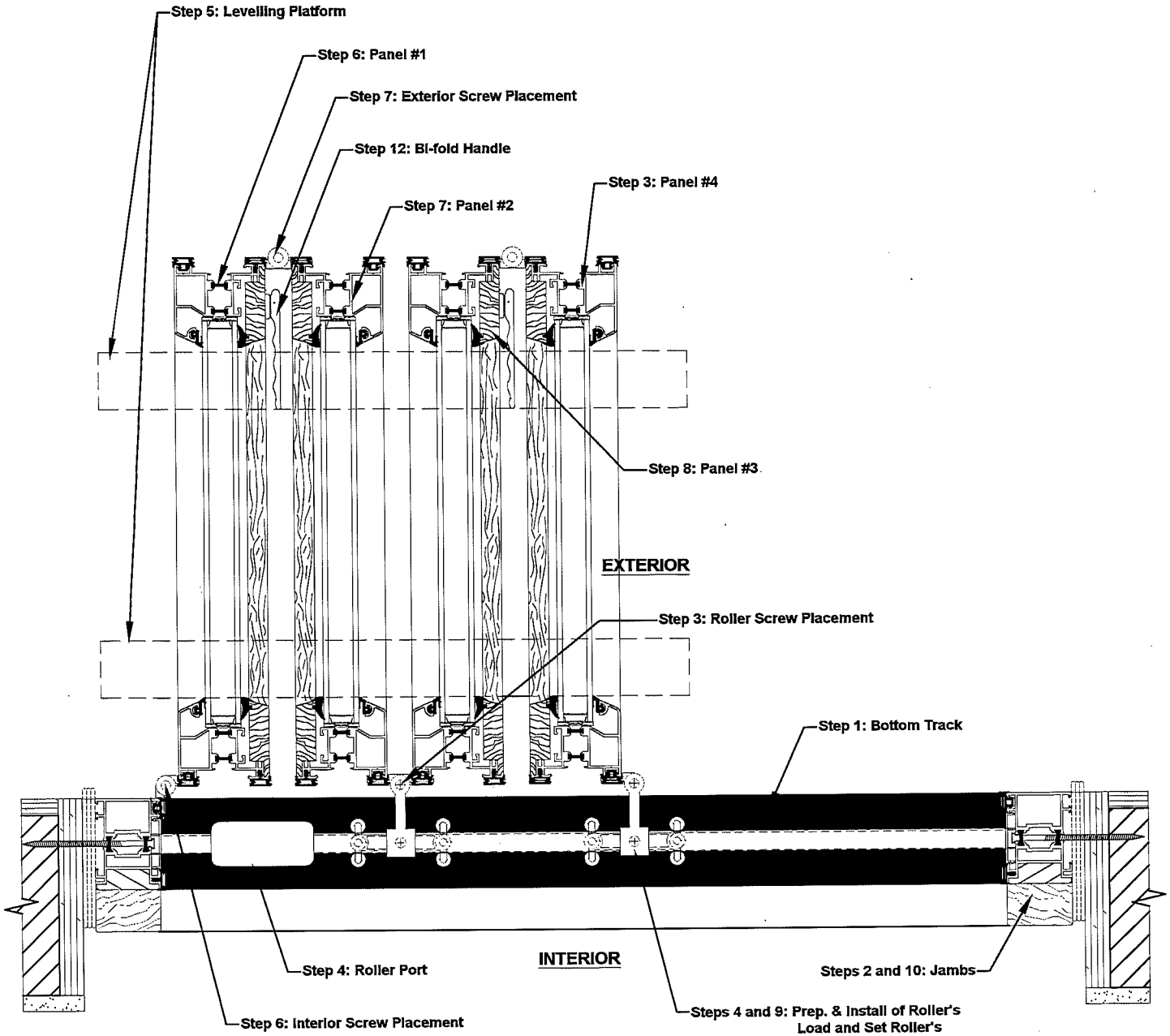

Installation Instructions for FD73 Configurations:

2 Panel, 4 Panel, 6 Panel, 8 Panel, and 10 Panel

BE SURE TO READ ALL INSTRUCTIONS PRIOR TO INSTALLING YOU DOOR UNIT

Step 1. Bottom Track.

- a) Make sure the opening is made to the correct dimensions as per the sign-off drawing included as well as waterproofed to code requirements. Install bottom track with roller port on the stacking side and oak rebate facing the interior.
- b) Place bottom track in the rebate cut out, with the oak sill to the interior and roller port to the stacking side and center it within the RO and mark where the pre-drilled holes are.
- c) Remove the bottom track, and where you marked the pre-drilled holes; place the needed number of shims (use shims provided) so that the oak rebate will be flush with interior finished floor. Using a laser level and tape measure make sure that shims are level along the rebate in both directions.
- d) Place the bottom track in the rebate and on the shims you have now set level and to the required height. Making sure to mount the track flush to the exterior face sheeting (typical). Using screws provided (#10 x 2 1/2" SS pan head) Screw both ends of the track as well as the center (silicon screws before installing to ensure no water infiltration), and re check to make sure that the bottom track is sitting firm and level in both directions, as well as straight.
- e) Once you have ensured the track is level and straight proceed to put the remaining bottom track screws in.

Step 2. Jambs.

- a) Identify the hinge jamb for stacking side and double gasket jamb side as per FIG 1 - 2.
NOTE: Measure jamb length from top and bottom of aluminum (do not include the protrusion of the jamb inserts) and note it space provided in **Step 3.** (a)

FD 73 HINGE JAMB LEFT

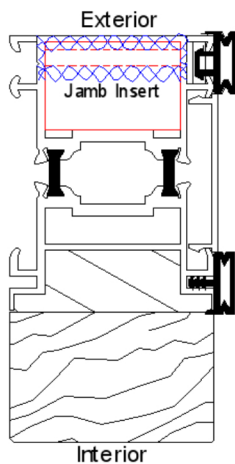

FIG 1.

Used for all configurations

FD 73 Double Gasket Jamb

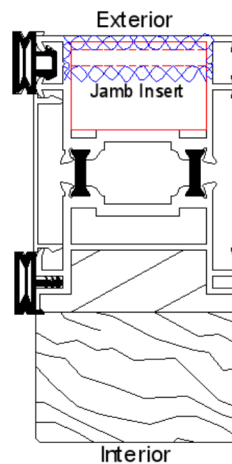

FIG 2.

Used for all configurations
 For Right hand configurations use mirror image

- b) Caulk ends of both jambs as shown in Fig's 1 thru 3 depicted by squiggly lines (FIG 3 on next page). Pre screw in 2 (#10 x 4" FH Screw) into top and bottom pre-drilled holes on both jambs for ease of installation.

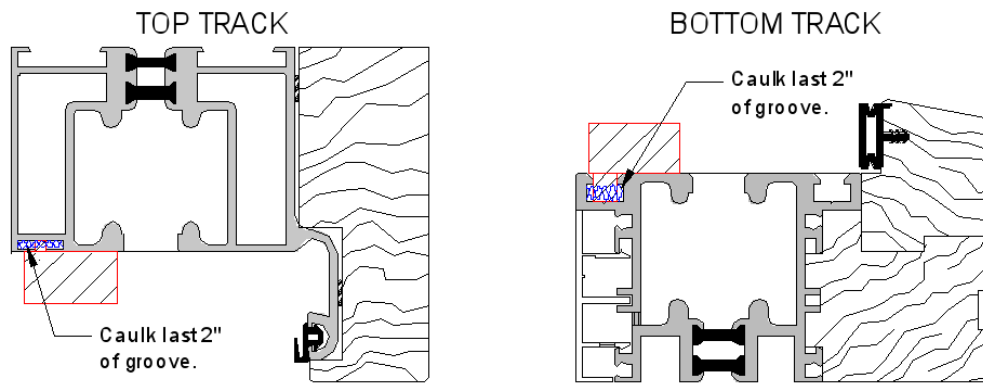

FIG 3.

- c) Caulk the last 2" of the outside groove of both top and bottom tracks before inserting jambs, as shown in FIG 3.
- d) Each jamb has a jamb insert top and bottom; the thicker Insert is at the bottom of the jamb and will be inserted into the outside groove of the bottom track. The thinner jamb insert is at the top of the jamb and will insert into the outside groove of the top track (See FIG. 3).
- e) Screw both jambs square and plum to bottom track using screws provided (#10 x 4" Flathead ss). Only screw in top and bottom of jambs (leave the rest till Step 11.)

Step 3. Top Track

- a) Set top track on top of jambs; make sure that the top track is tight to top of jambs (Use cedar shims above jambs).
 - ❖ **Jamb length** _____
- b) First will be to place shims and screw in the center of the top track. To do this, take the above **Jamb Length** and depending on the length of your door, add the necessary camber, see below example for camber. Using screws #14 x 3" round head screw and shims provided screw center of track. Once that has been set, screw and place all other top track screws.
 - ❖ Recommend having a 1/16" (1.5mm) camber per 8' of top track.

Ex. An 8' door is recommended to have a 1/16" (1.5mm) camber and from 16' up it is recommend having a 1/8" (3mm) camber, anything above 16' use an 1/8" chamber no larger.
- c) Remove any access caulking on the exterior face of the top and bottom jambs where they meet with the top and bottom track.

Step 4. Rollers

- a) Using a 2.5mm allen key loosen two setscrews on the side of all the rollers, as shown in FIG 4.
- b) Using a 5mm allen key to adjust the roller 1/2" (12.5mm) for top track roller(s) and 5/8" (15.5mm) for the bottom track roller(s) using the adjustment screw, as shown in FIG 4.
- c) Insert all rollers into the roller port (cut out in track) of the top and bottoms tracks. (***It is critical to insert rollers before installation of the panels**). Tilt the roller assembly as you place it into the roller port.
- d) Two rollers will have a pin and two bushing to remove before installation. Put these parts into a box for use in Step 9.
- e) Once in, push rollers to far end of stacking side. That way when installing the panels, the top of the panels do not hit the rollers.

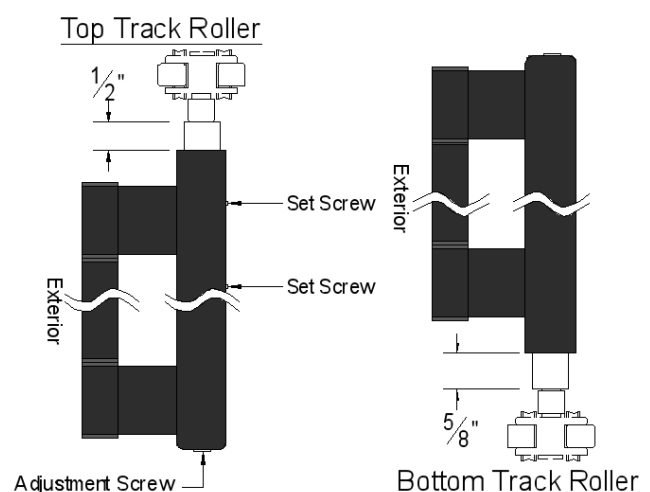
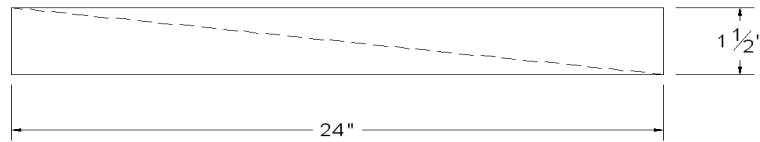

FIG 4.

Step 5. Levelling Platform

- Using a leveling platform will help; level the panels, align the hinges, and support the panels for ease of installation.
- Make 2 pairs of tapered shims out of 1x4" or 2x4" depending on the clearance between the bottom of the door panels and the Patio or exterior floor. The shims will allow you to easily adjust the leveling platform to the required height. (See Elevation View Drawing, Pg. 5)
- Set the levelling platform to be 5/16" – 3/8" (8-9mm) above the bottom track. Ensure the platform is solid and not going to easily move. Platform should be long enough to span the thickness of all panels.



- It is critical to have the proper spacing of 5/16" - 3/8" (8-9mm) for the door to operate properly. (Recommend using the key stock provided in the HOPPE handle kit.) Using the key stock, place it on top of the bottom track, it should slide just under the bottom of the panel which ensures that it is 8-9mm above the top of the bottom track.**
- b)

Step 6. Installation of **panel #1**. (Numbering of panels is determined from roller port side.)

- Place panel #1 (which has a single bi-fold point with a 2-point lock assembly) feather gasket side down on the levelling platform, perpendicular to the bottom track and close enough to the hinge jamb to align and attach the hinges that are already attached to door panel #1.
- Attach doors to jamb using machine screws provided and shown below. Do not move the hinges that are attached to panel #1. If the hinges do not exactly line up with the backer plates in the jamb, you can move the backer plates within the jamb.

- ❖ Exterior hinge, 3 - #10 x 1 1/4" SS tec
- ❖ Interior hinge, 3 - #10 x 3/8" FH SS

SCREW PLACEMENT

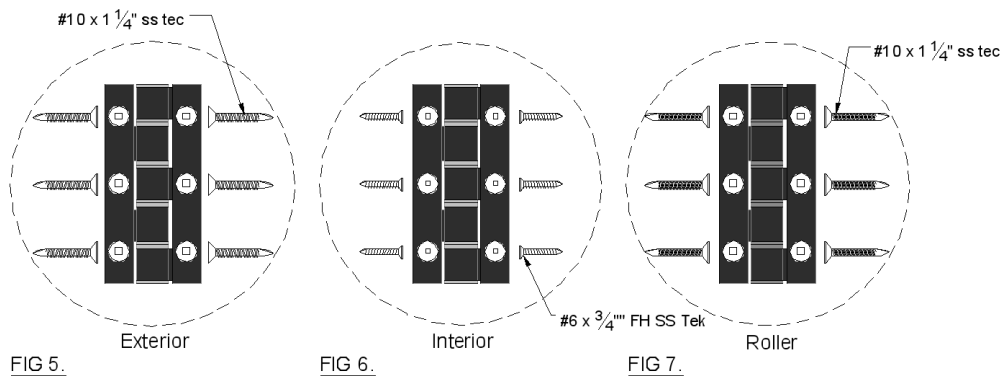

- Double check that panel is set to the correct height above the bottom track, as it is crucial for the installation of the following panels.

Step 7. Installation of **panel #2**.

- Place panel #2 interior face - to - interior face and feather gasket side down.
- Using a straight edge on top, ensure that the panels are inline and level.
- Attach interior hinges using screws provided (3 - #10 x 3/8" FH SS). See FIG 6.
- Attach the top and bottom rollers to the panel (make sure rollers are set to the correct dimension as per page 4 FIG 4.) using screws provided (See FIG 7.). Make sure that the roller hinges are set 2 3/8" (60mm) from the bottom of the panel and 2 3/8" (60mm) from the top of the panel.
- Attach top roller to the panel first, ensuring that the panel is level and straight with panel one. Then attach bottom roller, once both rollers have been installed attach middle hinges in between as per FIG 5.

Step 8. Installation of **panel #3.**

- a) Place panel #3 exterior face – to – exterior face and feather gasket side down.
- b) Using a straight edge on top, ensure the panels are inline and level.
- c) For attaching rollers to panels repeat Step 7: (d) and (e)
- d) Attach the middle hinges as per FIG 5.

Step 9. Installation of **panel #4.**

- a) Place panel #4 interior face - to - interior face and feather gasket side down.
- b) Using a straight edge on top, ensure that the panels are inline and level.
- c) Attach interior hinges using screws provided (3 - #10 x 3/8" FH SS). See Fig 6.
- d) Using parts from Step 4. (d) Attach top and bottom rollers for the last panel with half hinges attached.
- e) If you have a 6,8, or 10 panel unit repeat Steps 6 thru 8 as needed.

Step 10. Load and set all rollers.

- a) To remove the leveling platform, you can use the roller assembly to lift the panels. To do this use the adjustment screw on both top and bottom rollers simultaneously. Ensuring the door panels are sitting 5/16" – 3/8" (8-9mm) above the bottom track.
- b) Adjust the bottom roller until it starts to load at that point give it one more 1/2" to 3/4" turn. How smooth the panels are sliding will determine the amount of the last turn when loading the bottom roller.
- c) Test the door for smooth operation.
- d) If the door operates smoothly, remove setscrews on the rollers and use a 1/8" drill bit to make an indentation for each of the setscrews to fit back in firmly, to prevent slippage.

Step 11. Adjusting the jambs.

- a) Close the door all the way; this might require you to adjust the jambs to get the required 1/2" gap between the jamb and the panel, metal to metal.
- b) Add or remove shims from jambs as needed, once you have the desired resistance when closing, put the middle shims and jamb screws in (Use screws provided #10 x 4" flat head screws).
- c) Once all adjustments are complete, clip in the black plastic jamb infill's covering the screws.

Step 12. Installation of **Bi-fold Handle**

- a) Hold handle at a horizontal position and insert the shank into the door.
- b) Make sure the back plate is square to door panel.
- c) Secure firmly using screws provided (2 - #8 x 1" FH Wood screw).

Step 13. Waterproofing

- a) Waterproof as per BC Building Code.
- b) See attached plan view and elevation view drawings for details on where waterproofing is needed.

*** PLEASE NOTE ***

IF YOU OPERATE THE DOOR OUT OF SEQUENCE
YOU WILL DAMAGE THE GASKETS

**Should you require assistance please call Jordin Hartmann
@ Cell: 1-(250)-869-6367 or Office: 1-(250)-448-6418**

HOW TO OPERATE YOUR BI-FOLD DOOR

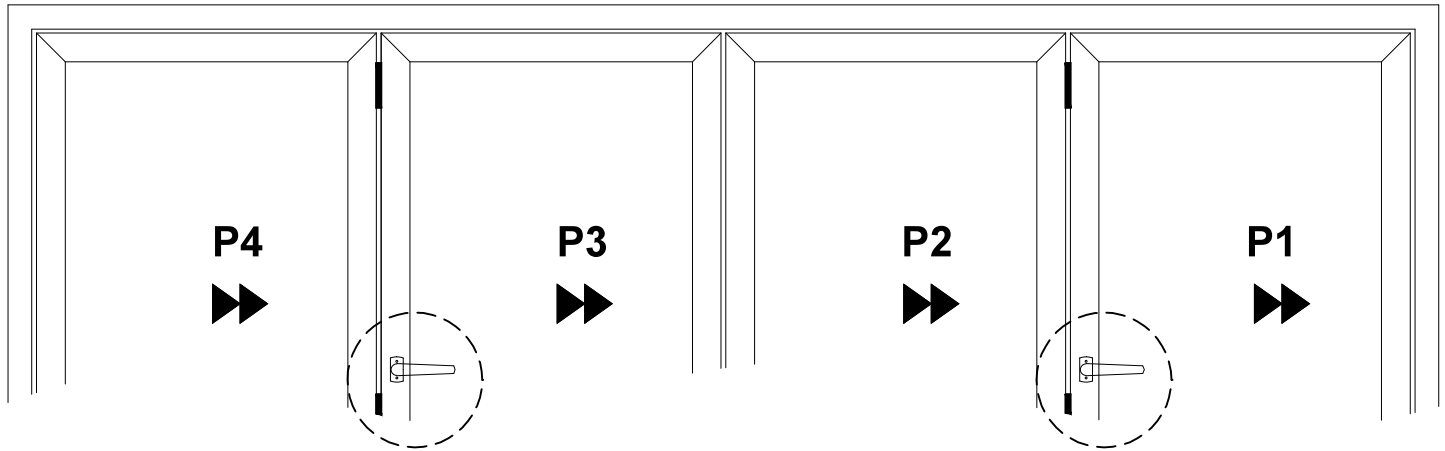

1. Starting from main swing panel, OPERATE lever handle then outward open MAIN SWING PANEL inline with adjacent center panel, allowing it to clip in to stop.
2. Release Bi-Fold handle(s) then PUSH center panel adjacent to end panel.
3. Fold all panels back against the wall for maximum opening.

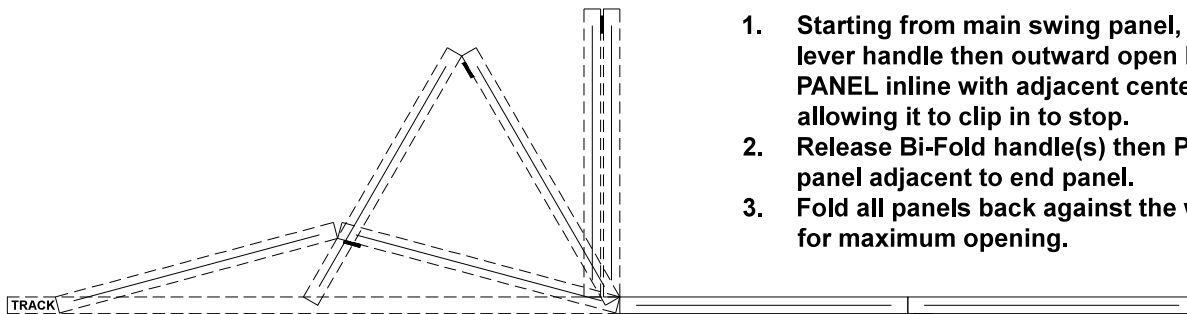

Stage 1: (Inside View)
Swing door opens first
Fold Fully back in-line

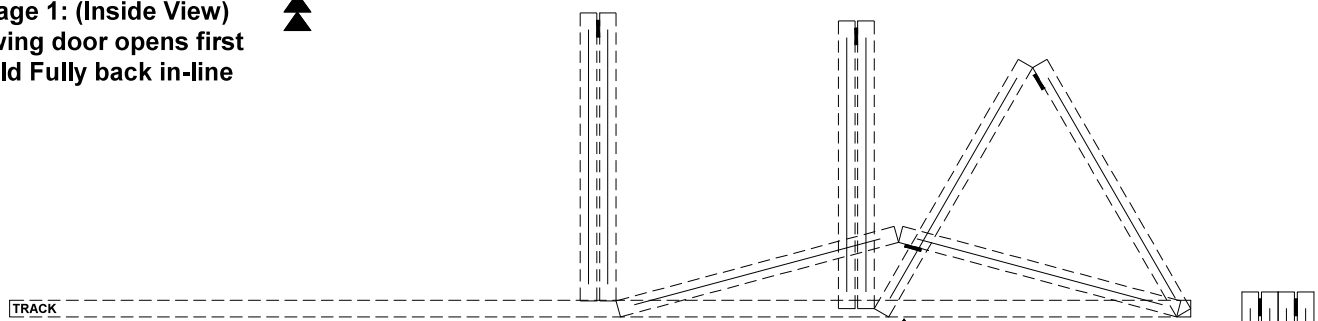

Stage 2: (Inside View)
Push to collapse out, Push
from Roller side to control door

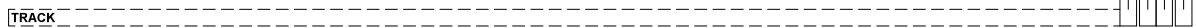

Stage 3: (Inside View) Fully open position

HOW TO OPERATE YOUR BI-FOLD DOOR

1. Hold panels 2 & 3 and walk in the direction of the track
2. The rollers are utilized giving a smooth closure to the Bi-Fold door.
3. Close and secure the end swing panel

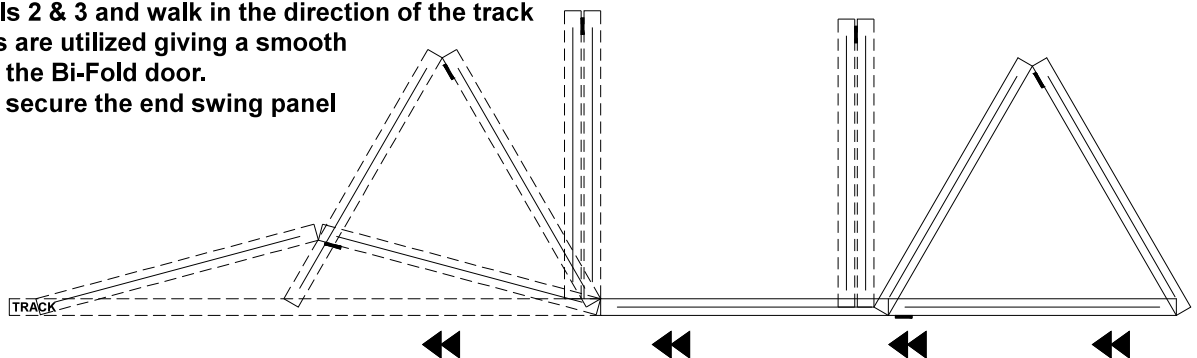

HOW TO OPERATE YOUR BI-FOLD DOOR (RIGHT HAND STACKING OUTWARD OPENING)

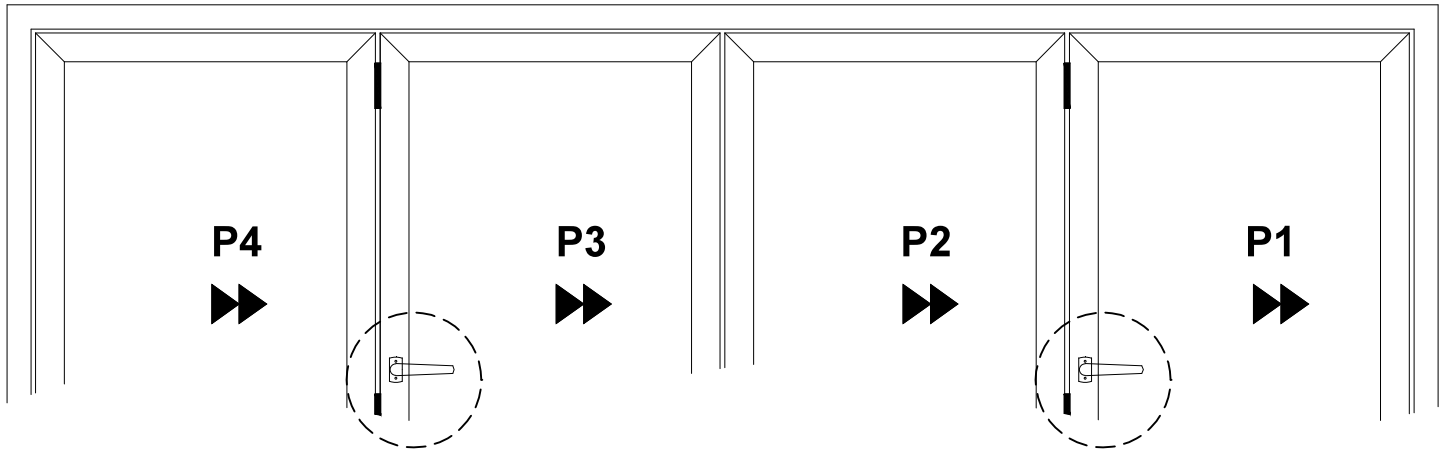

HOW TO OPERATE YOUR BI-FOLD HANDLE

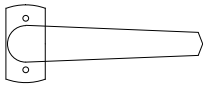

1.) Bi-Fold Handle in Locked Position.

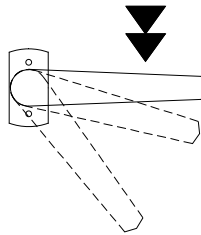

2.) To Open Bi-Fold Push Handle Down 45 Degrees and release then push out.

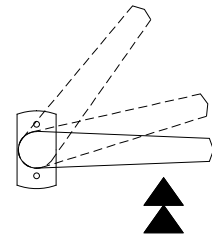

3.) To Close Bi-Fold, Pull Up 45 Degrees.